

SVS側溝本体500構造図(T-25)

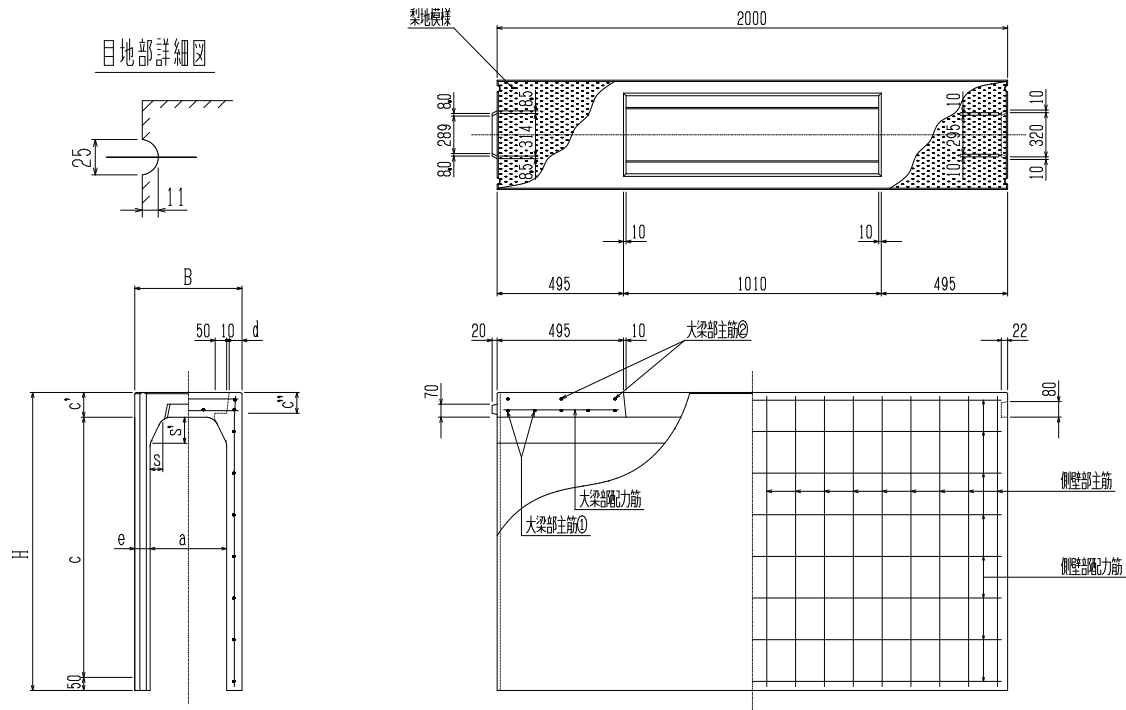

寸法 * 重量表

呼び名	寸法 (mm)										配筋						参考重量 (kg)				
	B	H	a	c	c'	c''	d	e	s	s'	側壁部		大梁部								
											主筋	配力筋	主筋 ①		主筋 ②			配力筋			
													径(mm)	数	径(mm)	数			径(mm)	数	径(mm)
500 × 400	640	575	500	400	125	110	65	70	60	120	D 6	13	4.0	4	D 6	8	D10	3	4.0	6	563
× 500	640	675	500	500	125	110	65	70	60	120	D 6	14	4.0	5	D 6	8	D10	3	4.0	6	629
× 600	640	775	500	600	125	110	65	70	60	120	D 6	14	4.0	5	D 6	8	D10	3	4.0	6	695
× 700	640	875	500	700	125	110	65	70	60	120	D 6	14	4.0	6	D 6	8	D10	3	4.0	6	760
× 800	640	975	500	800	125	110	65	70	60	120	D 6	14	4.0	7	D 6	8	D10	3	4.0	6	826
× 900	640	1075	500	900	125	110	65	70	60	120	D 6	16	4.0	7	D 6	8	D10	3	4.0	6	892
× 1000	640	1175	500	1000	125	110	65	70	60	120	D 6	18	4.0	8	D 6	8	D10	3	4.0	6	958
× 1100	640	1275	500	1100	125	110	65	70	60	120	D 6	21	4.0	9	D 6	8	D10	3	4.0	6	1024
× 1200	640	1375	500	1200	125	110	65	70	60	120	D10	11	5.0	9	D 6	8	D10	3	4.0	6	1089
× 1300	640	1475	500	1300	125	110	65	70	60	120	D10	13	5.0	10	D 6	8	D10	3	4.0	6	1155
× 1400	640	1575	500	1400	125	110	65	70	60	120	D10	16	5.0	11	D 6	8	D10	3	4.0	6	1221