

# VS側溝本体250構造図(T-25)

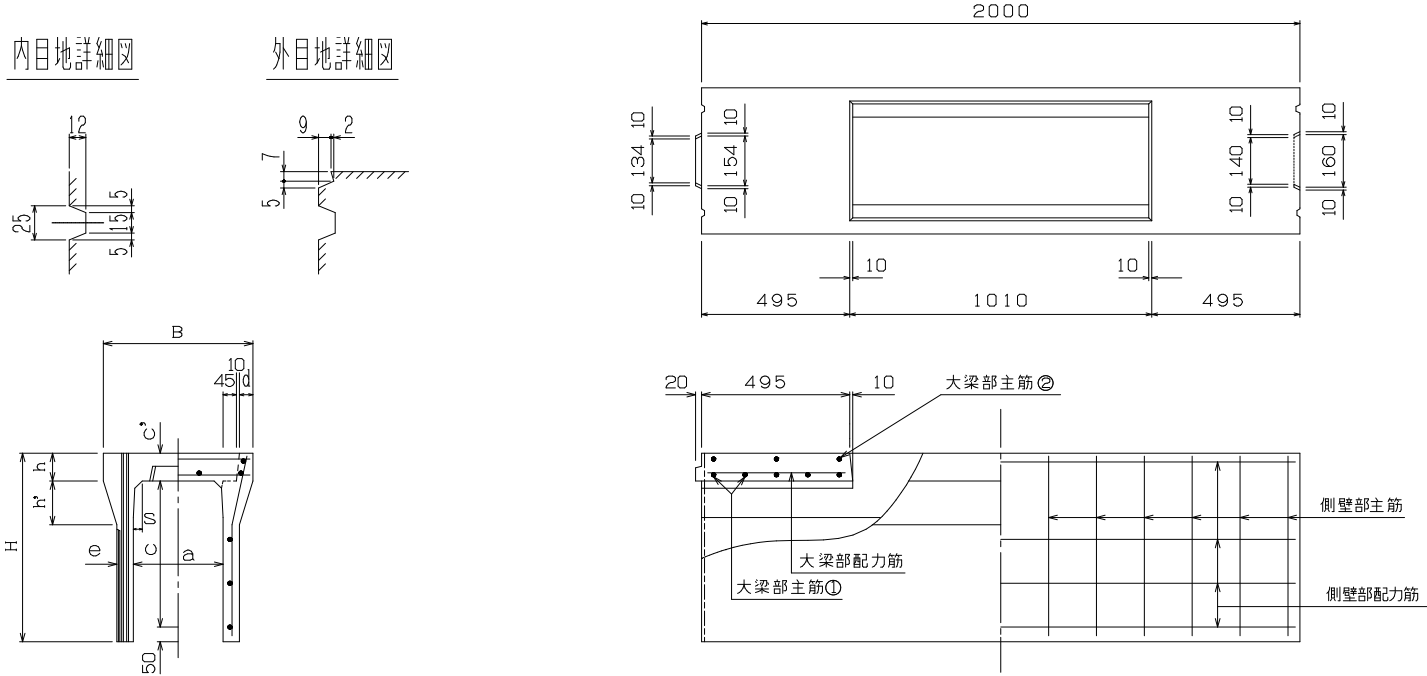

寸法 \* 配筋 \* 重量表

呼び名	寸法 (mm)										配筋								参考重量 (kg)		
	B	H	a	c	c'	d	e	h	h'	s	側壁部		大梁部								
											主筋	配力筋	主筋①	主筋②	配力筋	主筋	配力筋	主筋		配力筋	主筋
径(mm)	数	径(mm)	数	径(mm)	数	径(mm)	数	径(mm)	数	径(mm)	数	径(mm)	数	径(mm)	数	径(mm)	数	径(mm)	数		
250 × 250	450	390	250	250	90	45	50	90	100	25	4.0	12	3.2	4	D 6	5	D 6	3	4.0	4	286
× 300	450	440	250	300	90	45	50	90	100	25	4.0	13	3.2	4	D 6	5	D 6	3	4.0	4	310
× 400	450	540	250	400	90	45	50	90	100	25	5.0	13	3.2	4	D 6	5	D 6	3	4.0	4	357
× 500	450	640	250	500	90	45	65	90	100	30	5.0	14	3.2	5	D 6	5	D 6	3	4.0	4	474
× 600	450	740	250	600	90	45	65	90	100	30	5.0	17	3.2	5	D 6	5	D 6	3	4.0	4	535
× 700	450	840	250	700	90	45	65	90	100	30	5.0	21	3.2	6	D 6	5	D 6	3	4.0	4	596
× 800	450	940	250	795	95	45	75	90	100	35	D 6	13	4.0	6	D 6	5	D 6	3	4.0	4	738
× 900	450	1040	250	895	95	45	75	90	100	35	D 6	14	4.0	7	D 6	5	D 6	3	4.0	4	808
× 1000	450	1140	250	995	95	45	75	90	100	35	D 6	16	4.0	8	D 6	5	D 6	3	4.0	4	879

※ 呼び名 250×250～400 のジョイント部目地は内目地のみとなります。

東海商事ブロック工業(株)

# VS側溝本体300構造図(T-25)

内目地詳細図

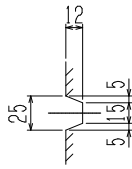

外目地詳細図

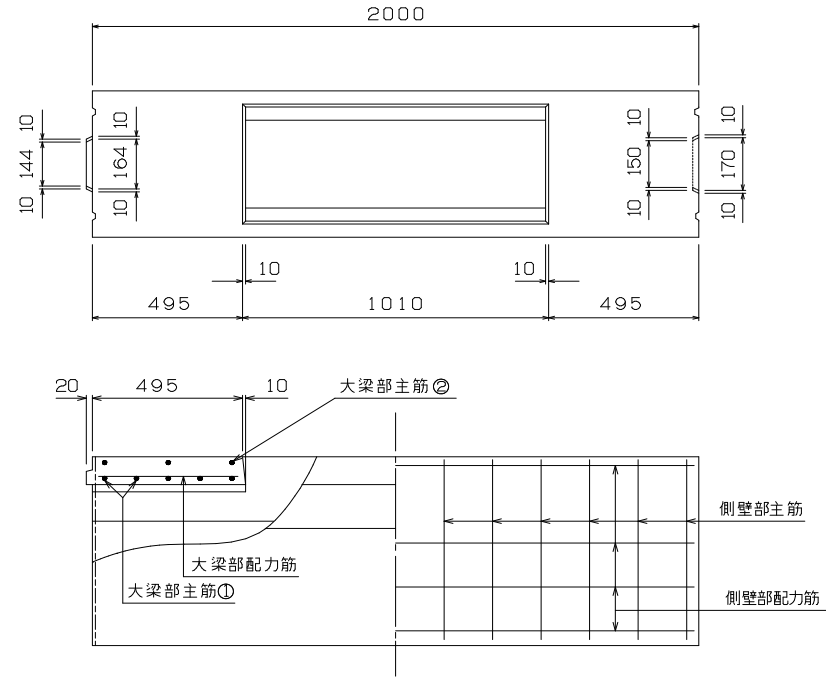
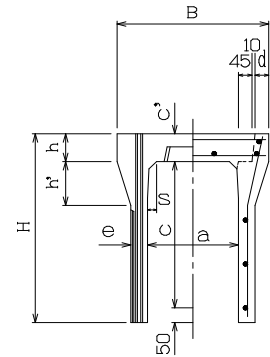
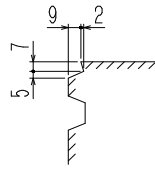

寸法 \* 配筋 \* 重量表

呼び名	寸法 (mm)										配筋部						参考重量 (kg)				
	B	H	a	c	c'	d	e	h	h'	s	側壁部		大梁部								
											主筋	配力筋	主筋①	主筋②	配力筋						
径(mm)	数	径(mm)	数	径(mm)	数	径(mm)	数	径(mm)	数	径(mm)	数	径(mm)	数	径(mm)	数						
300 × 300	500	445	300	300	95	45	50	95	100	25	4.0	13	3.2	4	D 6	5	D 6	3	4.0	4	322
× 400	500	545	300	400	95	45	55	95	150	30	5.0	13	3.2	4	D 6	5	D 6	3	4.0	4	399
× 500	500	645	300	500	95	45	55	95	150	30	5.0	14	3.2	5	D 6	5	D 6	3	4.0	4	450
× 600	500	745	300	600	95	45	65	95	160	35	5.0	17	3.2	5	D 6	5	D 6	3	4.0	4	558
× 700	500	845	300	700	95	45	65	95	160	35	5.0	21	3.2	6	D 6	5	D 6	3	4.0	4	618
× 800	500	945	300	800	95	45	75	95	170	40	D 6	13	4.0	6	D 6	5	D 6	3	4.0	4	754
× 900	500	1045	300	900	95	45	75	95	170	40	D 6	14	4.0	7	D 6	5	D 6	3	4.0	4	824
× 1000	500	1145	300	1000	95	45	85	95	180	45	D 6	16	4.0	8	D 6	5	D 6	3	4.0	4	986
× 1100	500	1245	300	1100	95	45	85	95	180	45	D 6	18	4.0	9	D 6	5	D 6	3	4.0	4	1065
× 1200	500	1345	300	1185	110	45	100	-	-	45	D 6	20	4.0	9	D 6	5	D10	3	4.0	4	1303
× 1300	500	1445	300	1285	110	45	100	-	-	45	D 6	22	4.0	10	D 6	5	D10	3	4.0	4	1395
× 1400	500	1545	300	1385	110	45	100	-	-	45	D10	13	5.0	11	D 6	5	D10	3	4.0	4	1487
× 1500	500	1645	300	1485	110	45	100	-	-	45	D10	14	5.0	11	D 6	5	D10	3	4.0	4	1579
× 1600	500	1745	300	1585	110	45	100	-	-	45	D10	16	5.0	12	D 6	5	D10	3	4.0	4	1671
× 1700	500	1845	300	1685	110	45	100	-	-	45	D10	18	5.0	12	D 6	5	D10	4	4.0	4	1763
× 1800	500	1945	300	1785	110	45	100	-	-	45	D10	20	5.0	13	D 6	5	D10	4	4.0	4	1855

※ 呼び名 300 × 300～500のジョイント部目地は内目地のみとなります。

# VS側溝本体400構造図(T-25)

内目地詳細図

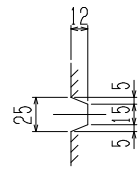

外目地詳細図

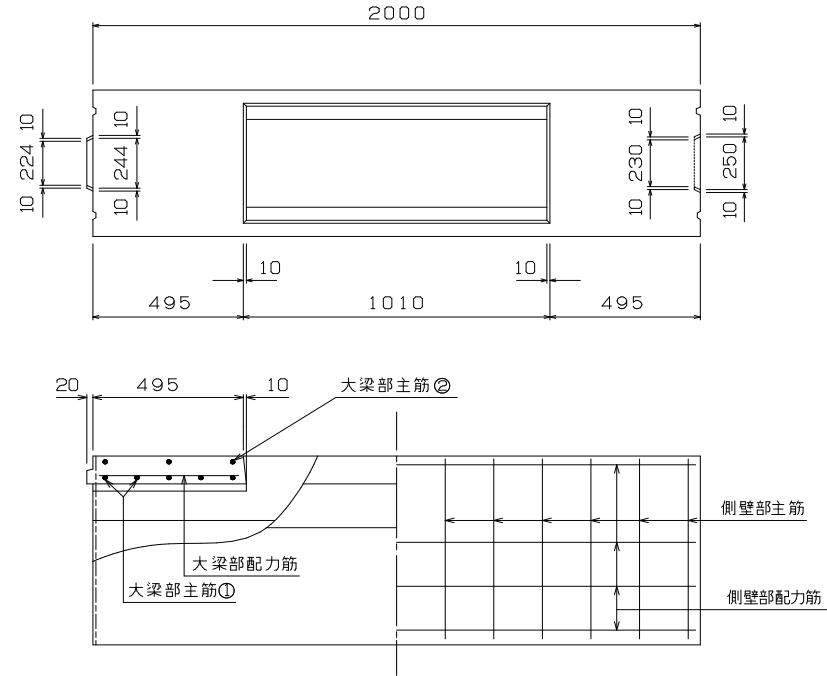
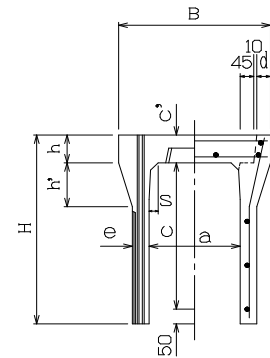
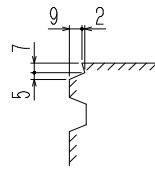

寸法 \* 配筋 \* 重量表

呼び名	寸法 (mm)										配筋						参考重量 (kg)				
	B	H	a	c	c'	d	e	h	h'	s	側壁部		大梁部								
											主筋	配力筋	主筋①	主筋②	配力筋						
径(mm)	数	径(mm)	数	径(mm)	数	径(mm)	数	径(mm)	数	径(mm)	数	径(mm)	数								
400 × 400	610	560	400	400	110	50	60	110	160	40	5.0	13	3.2	4	D 6	7	D 6	3	4.0	5	476
× 500	610	660	400	500	110	50	60	110	160	40	5.0	14	3.2	5	D 6	7	D 6	3	4.0	5	532
× 600	610	760	400	600	110	50	60	110	160	40	5.0	17	3.2	5	D 6	7	D 6	3	4.0	5	588
× 700	610	860	400	700	110	50	70	110	170	45	5.0	21	3.2	6	D 6	7	D 6	3	4.0	5	710
× 800	610	960	400	800	110	50	70	110	170	45	D 6	13	4.0	6	D 6	7	D 6	3	4.0	5	775
× 900	610	1060	400	900	110	50	80	110	180	50	D 6	14	4.0	7	D 6	7	D 6	3	4.0	5	924
× 1000	610	1160	400	1000	110	50	80	110	180	50	D 6	16	4.0	8	D 6	7	D 6	3	4.0	5	999
× 1100	610	1260	400	1100	110	50	90	110	190	55	D 6	18	4.0	9	D 6	7	D 6	3	4.0	5	1175
× 1200	610	1360	400	1200	110	50	90	110	190	55	D 6	20	4.0	9	D 6	7	D 6	3	4.0	5	1259
× 1300	610	1460	400	1285	125	50	105	—	—	60	D 6	22	4.0	10	D 6	7	D10	3	4.0	5	1555
× 1400	610	1560	400	1385	125	50	105	—	—	60	D10	13	5.0	11	D 6	7	D10	3	4.0	5	1653
× 1500	610	1660	400	1485	125	50	105	—	—	60	D10	14	5.0	11	D 6	7	D10	3	4.0	5	1752
× 1600	610	1760	400	1585	125	50	105	—	—	60	D10	16	5.0	12	D 6	7	D10	3	4.0	5	1850
× 1700	610	1860	400	1685	125	50	105	—	—	60	D10	18	5.0	12	D 6	7	D10	3	4.0	5	1949
× 1800	610	1960	400	1785	125	50	105	—	—	60	D10	20	5.0	13	D 6	7	D10	3	4.0	5	2047
× 1900	610	2060	400	1885	125	50	105	—	—	60	D13	13	D 6	13	D 6	7	D10	4	4.0	5	2146
× 2000	610	2160	400	1985	125	50	105	—	—	60	D13	15	D 6	14	D 6	7	D10	4	4.0	5	2245
× 2100	610	2260	400	2085	125	50	105	—	—	60	D13	17	D 6	14	D 6	7	D10	5	4.0	5	2344
× 2200	610	2360	400	2185	125	50	105	—	—	60	D13	19	D 6	15	D 6	7	D10	5	4.0	5	2443

※ 呼び名 400 × 400 ~ 600 のジョイント部目地は内目地のみとなります。

# VS側溝本体500構造図(T-25)

内目地詳細図

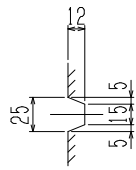

外目地詳細図

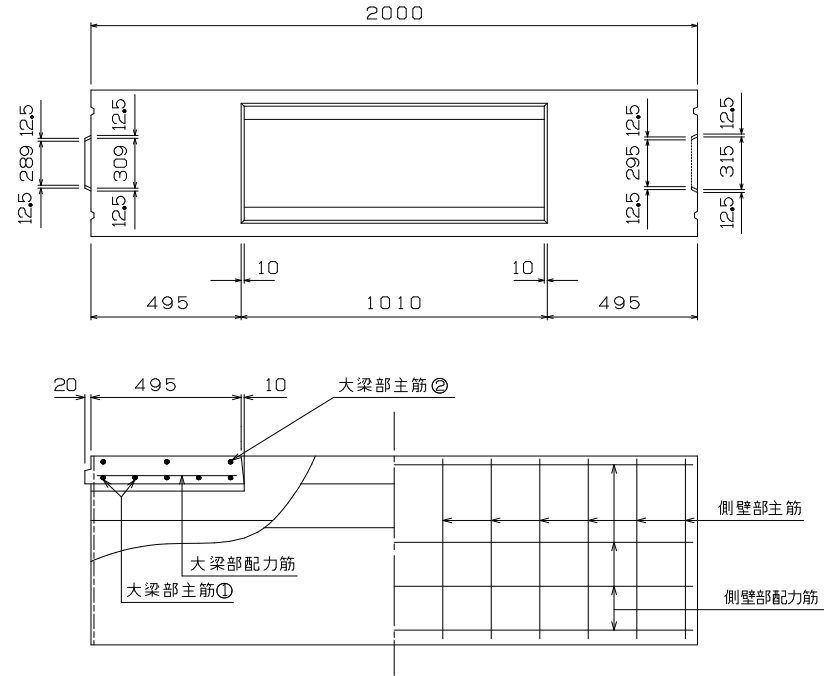
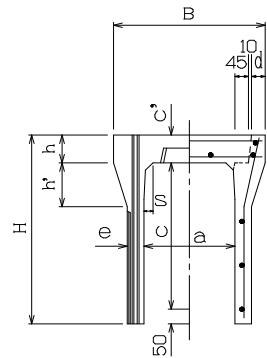
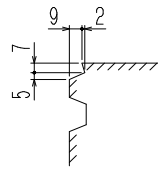

寸法 \* 配筋 \* 重量表

呼び名	寸法 (mm)										配筋						参考重量 (kg)				
	B	H	a	c	c'	d	e	h	h'	s	側壁部		大梁部								
											主筋	配力筋	主筋 ①		主筋 ②			配力筋			
													径(mm)	数	径(mm)	数		径(mm)	数	径(mm)	数
500 × 400	720	575	500	400	125	55	70	125	170	50	5.0	13	3.2	4	D 6	8	D 6	3	4.0	6	580
× 500	720	675	500	500	125	55	70	125	170	50	5.0	14	3.2	5	D 6	8	D 6	3	4.0	6	645
× 600	720	775	500	600	125	55	70	125	170	50	5.0	19	3.2	5	D 6	8	D 6	3	4.0	6	710
× 700	720	875	500	700	125	55	70	125	170	50	5.0	22	3.2	6	D 6	8	D 6	3	4.0	6	775
× 800	720	975	500	800	125	55	70	125	170	50	D 6	13	4.0	7	D 6	8	D 6	3	4.0	6	840
× 900	720	1075	500	900	125	55	85	125	180	60	D 6	15	4.0	7	D 6	8	D 6	3	4.0	6	1032
× 1000	720	1175	500	1000	125	55	85	125	180	60	D 6	16	4.0	8	D 6	8	D 6	3	4.0	6	1111
× 1100	720	1275	500	1100	125	55	85	125	180	60	D 6	18	4.0	9	D 6	8	D 6	3	4.0	6	1190
× 1200	720	1375	500	1200	125	55	95	125	190	70	D 6	20	4.0	9	D 6	8	D 6	3	4.0	6	1383
× 1300	720	1475	500	1300	125	55	95	125	190	70	D 6	22	4.0	10	D 6	8	D 6	3	4.0	6	1471
× 1400	720	1575	500	1400	125	55	95	125	190	70	D10	13	5.0	11	D 6	8	D 6	3	4.0	6	1559
× 1500	720	1675	500	1500	125	55	110	-	-	75	D10	14	5.0	11	D 6	8	D10	3	4.0	6	1860
× 1600	720	1775	500	1600	125	55	110	-	-	75	D10	16	5.0	12	D 6	8	D10	3	4.0	6	1966
× 1700	720	1875	500	1700	125	55	110	-	-	75	D10	18	5.0	12	D 6	8	D10	3	4.0	6	2072
× 1800	720	1975	500	1800	125	55	110	-	-	75	D10	20	5.0	13	D 6	8	D10	3	4.0	6	2178
× 1900	720	2075	500	1900	125	55	110	-	-	75	D13	13	D 6	13	D 6	8	D10	4	4.0	6	2284
× 2000	720	2175	500	2000	125	55	110	-	-	75	D13	15	D 6	14	D 6	8	D10	4	4.0	6	2390
× 2100	720	2275	500	2100	125	55	110	-	-	75	D13	17	D 6	14	D 6	8	D10	5	4.0	6	2496
× 2200	720	2375	500	2200	125	55	110	-	-	75	D13	19	D 6	15	D 6	8	D10	5	4.0	6	2602

※ 呼び名 500 × 1500 ~ 2200 のジョイント部は両端共に凹型となります。

# VS側溝本体600構造図(T-25)

内目地詳細図

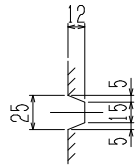

外目地詳細図

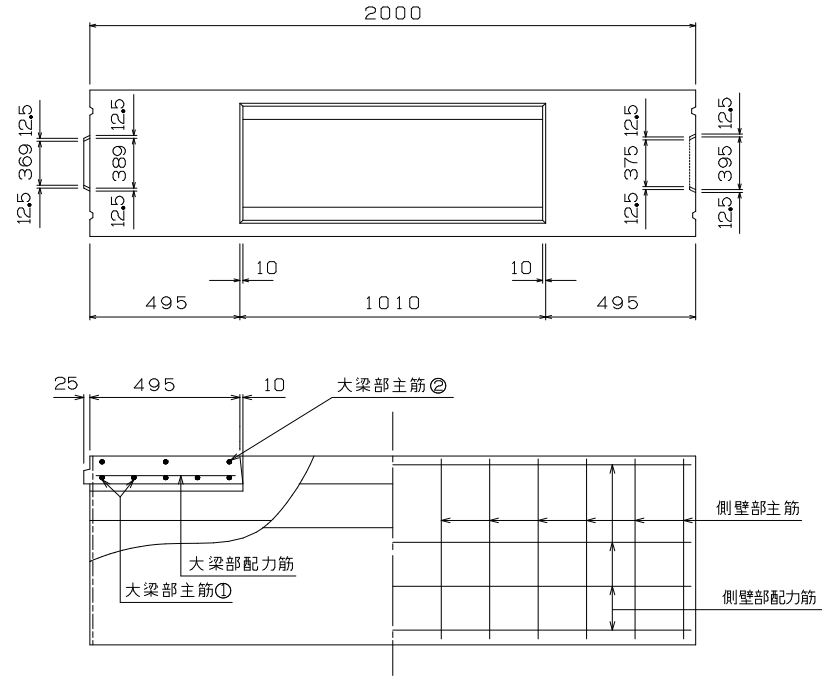
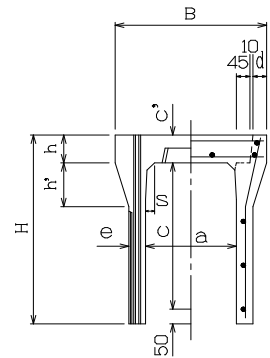
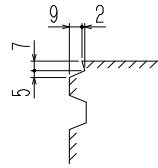

寸法\*配筋\*重量表

呼び名	寸法 (mm)										配筋						参考重量 (kg)				
	B	H	a	c	c'	d	e	h	h'	s	側壁部		大梁部								
											主筋	配力筋	主筋①	主筋②	配力筋						
径(mm)	数	径(mm)	数	径(mm)	数	径(mm)	数	径(mm)	数	径(mm)	数	径(mm)	数								
600 × 500	830	690	600	500	140	60	75	140	180	60	5.0	14	3.2	5	D10	4	D10	3	5.0	7	745
× 600	830	790	600	600	140	60	75	140	180	60	5.0	19	3.2	5	D10	4	D10	3	5.0	7	815
× 700	830	890	600	700	140	60	75	140	180	60	5.0	22	3.2	6	D10	4	D10	3	5.0	7	885
× 800	830	990	600	800	140	60	75	140	180	60	D 6	13	4.0	7	D10	4	D10	3	5.0	7	955
× 900	830	1090	600	900	140	60	75	140	180	60	D 6	15	4.0	7	D10	4	D10	3	5.0	7	1024
× 1000	830	1190	600	1000	140	60	90	140	190	70	D 6	16	4.0	8	D10	4	D10	3	5.0	7	1234
× 1100	830	1290	600	1100	140	60	90	140	190	70	D 6	18	4.0	9	D10	4	D10	3	5.0	7	1318
× 1200	830	1390	600	1200	140	60	90	140	190	70	D 6	20	4.0	9	D10	4	D10	3	5.0	7	1402
× 1300	830	1490	600	1300	140	60	100	140	200	80	D 6	22	4.0	10	D10	4	D10	3	5.0	7	1608
× 1400	830	1590	600	1400	140	60	100	140	200	80	D10	13	5.0	11	D10	4	D10	3	5.0	7	1701
× 1500	830	1690	600	1500	140	60	100	140	200	80	D10	14	5.0	11	D10	4	D10	3	5.0	7	1794
× 1600	830	1790	600	1600	140	60	100	140	200	80	D10	16	5.0	12	D10	4	D10	3	5.0	7	1887
× 1700	830	1890	600	1700	140	60	100	140	200	80	D10	18	5.0	12	D10	4	D10	3	5.0	7	1980
× 1800	830	1990	600	1800	140	60	100	140	200	80	D10	20	5.0	13	D10	4	D10	3	5.0	7	2073
× 1900	830	2090	600	1900	140	60	100	140	200	80	D13	13	D 6	13	D10	4	D10	4	5.0	7	2166
× 2000	830	2190	600	2000	140	60	100	140	200	80	D13	15	D 6	14	D10	4	D10	4	5.0	7	2259
× 2100	830	2290	600	2100	140	60	100	140	200	80	D13	17	D 6	14	D10	4	D10	5	5.0	7	2352
× 2200	830	2390	600	2200	140	60	100	140	200	80	D13	19	D 6	15	D10	4	D10	5	5.0	7	2445

※ 呼び名 600 × 1300 ~ 2200 のジョイント部は両端共に凹型となります。

東海商事ブロック工業(株)