

V S 側溝柵 250×500 構造図

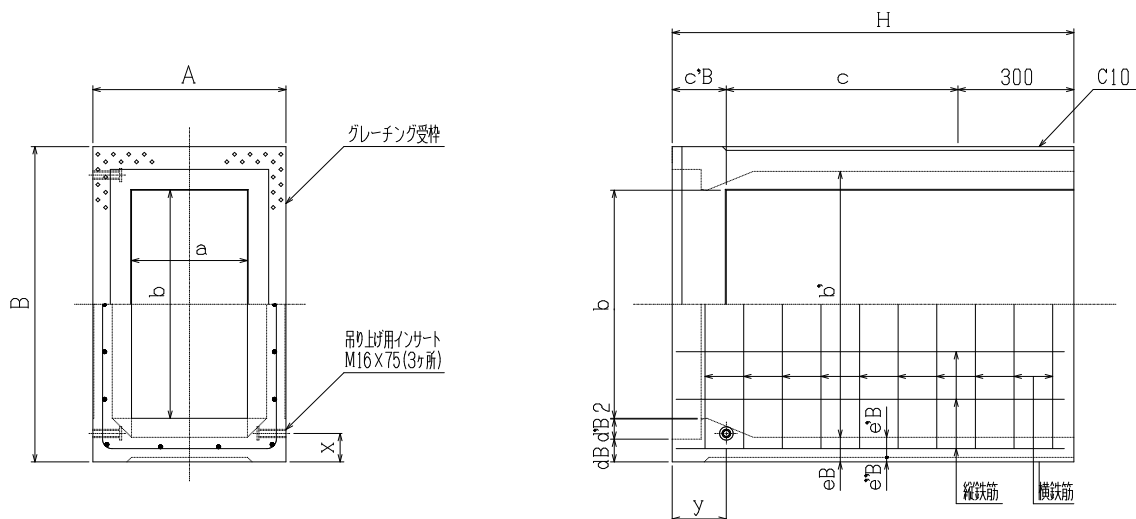

標準断面図

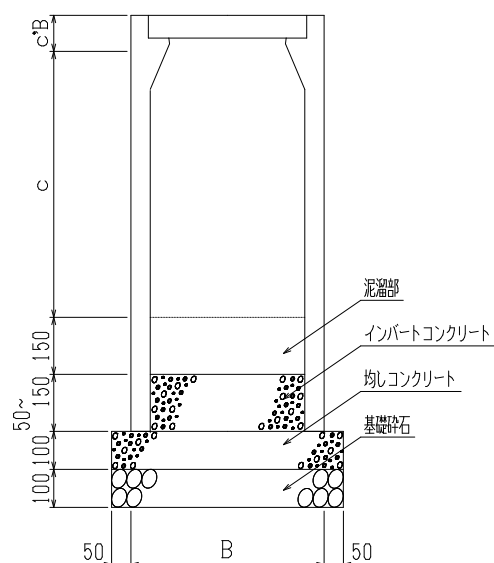
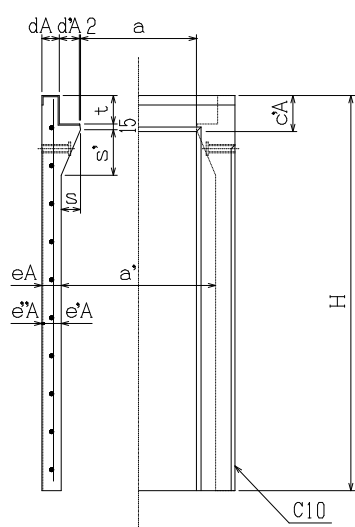

寸法 * 重量表

呼び名	寸法 (mm)																				参考重量 (kg)			
	a	b	c	A	B	H	a'	b'	c'A	c'B	dA	d'A	dB	d'B	eA	e'A	e''A	eB	e'B	e''B		t	s	s'
250 × 500 × 300	450	720	725	350	600	90	125	44.5	53.5	54.5	53.5	50	47.7	2.3	60	51	9	75	50	120	75	125	218	
250 × 500 × 400	450	720	825	350	600	90	125	44.5	53.5	54.5	53.5	50	47.7	2.3	60	51	9	75	50	120	75	125	244	
250 × 500 × 500	450	720	925	350	600	90	125	44.5	53.5	54.5	53.5	50	47.7	2.3	60	51	9	75	50	120	75	125	270	
250 × 500 × 600	450	720	1025	350	600	90	125	44.5	53.5	54.5	53.5	50	47.7	2.3	60	51	9	75	50	120	75	125	297	
250 × 500 × 700	450	720	1125	350	600	90	125	44.5	53.5	54.5	53.5	50	47.7	2.3	60	51	9	75	50	120	75	125	323	
250 × 500 × 800	450	720	1225	350	600	90	125	44.5	53.5	54.5	53.5	50	47.7	2.3	60	51	9	75	50	120	75	125	349	
250 × 500 × 900	450	720	1325	350	600	90	125	44.5	53.5	54.5	53.5	50	47.7	2.3	60	51	9	75	50	120	75	125	376	
250 × 500 × 1000	450	720	1425	350	600	90	125	44.5	53.5	54.5	53.5	50	47.7	2.3	60	51	9	75	50	120	75	125	402	
250 × 500 × 1100	450	720	1525	350	600	90	125	44.5	53.5	54.5	53.5	50	47.7	2.3	60	51	9	75	50	120	75	125	428	
250 × 500 × 1200	450	720	1625	350	600	90	125	44.5	53.5	54.5	53.5	50	47.7	2.3	60	51	9	75	50	120	75	125	455	
250 × 500 × 1300	450	720	1725	350	600	90	125	44.5	53.5	54.5	53.5	50	47.7	2.3	60	51	9	75	50	120	75	125	481	
250 × 500 × 1400	450	720	1825	350	600	90	125	44.5	53.5	54.5	53.5	50	47.7	2.3	60	51	9	75	50	120	75	125	507	